RF and Digital Signal Processing

Network Analyzer
Calibration Lab

Dan Van Winkle - SLAC

Dmitry Teytelman – Dimtel inc.

Student Name:

Introduction

Network Analyzers are powerful instruments capable of measuring 4 (or more) port s-parameters of various devices. They are also sometimes capable of measuring power sweeps and even frequency translation devices. All modern network analyzers are able to be “calibrated.” Using an error model and known standards, systematic errors of the analyzer can be removed from the measurement allowing the user to measure just their device. The main goal of this lab is to introduce you to the technique so that in later labs you will know how to do the calibration yourself...and will be able to take this bit of information home with you. If you already know how to do this...then this will be an easy lab for you.

Disclaimer – Most of this lab was ripped directly from Agilent Application Note 1287-3 which can be found at:

<http://cp.literature.agilent.com/litweb/pdf/5965-7709E.pdf>

Objectives

- 1) Learn a tiny bit of the theory behind calibration of network analyzers
- 2) Learn a bit about connector care.
- 3) Learn how to do a calibration
- 4) Investigate some limitations to calibration.

Preliminaries

1) Theory of Calibration (and the reasons why)

The effect of error correction on displayed data can be dramatic (Figure 1). Without error correction, measurements on a bandpass filter show considerable loss and ripple. The smoother, error-corrected trace produced by a twoport calibration subtracts the effects of systematic errors and better represents the actual performance of the device under test (DUT).

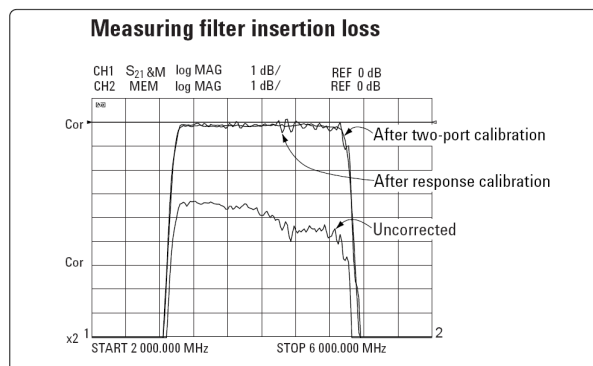

Figure 1. Response versus Two-Port Calibration

There are six types of systematic (time invariant) errors:

- Directivity and crosstalk errors relating to signal leakage
- Source and load impedance mismatches relating to reflections
- Frequency response errors caused by reflection and transmission tracking within the test receivers

(The full two-port error model includes all six of these terms for the forward direction and the same six (with different data) in the reverse direction, for a total of twelve error terms. This is why two-port calibration is often referred to as twelve-term error correction.)

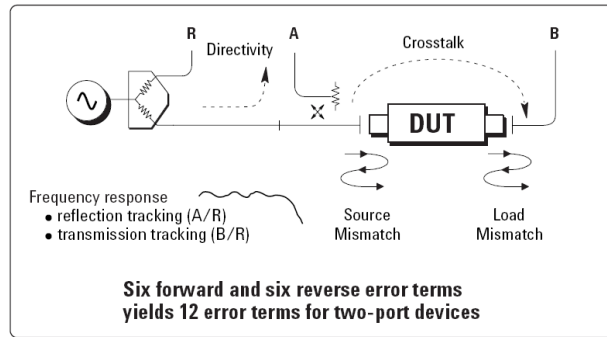

Figure 2. Systematic Measurement Errors

And for those of you that are real theory hounds, you can look at figure 3 to understand exactly what you are doing when you do a full two port cal (which we are about to do). Don't worry though, we will not ask you to recite any of this information. This is just to wet your appetite. If you want to know more, I suggest you visit the Agilent website where you can find more application notes than you can read in a week.

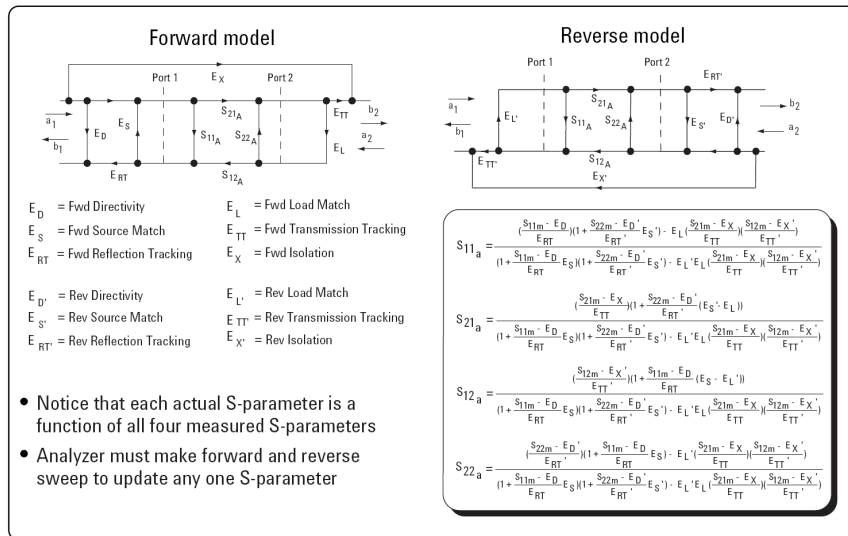

Figure 3. 2 Port Error Correction

There are two categories of calibration that we will consider in this lab, but we will actually only perform on (the full two port).

- **Response Calibration** - is simple to perform, but corrects for only a few of the 12 possible systematic error terms (namely, reflection and transmission tracking). Response calibration is a normalized measurement in which a reference trace is stored in the network analyzer's memory, and the stored trace is divided into measurement data for normalization.
- **Vector Calibration** - is a more thorough method of removing systematic errors. This type of error correction requires a network analyzer capable of measuring (but not necessarily displaying) phase as well as magnitude, and a set of calibration standards with known, precise electrical characteristics.

2) Connector Care

Most modern network analyzers have either 3.5 mm connectors or APC7 connectors. 3.5 mm connectors are precision connectors which are mode free up to 34 GHz. Since these connectors are precision and have air dielectric, they are VERY easy to damage!!!!

YOU MUST READ THE FOLLOWING SECTION BEFORE CONTINUING WITH THIS LAB!

Precision 3.5 mm microwave connectors are compatible with an SMA connector within its specification. Due to the variable quality of the SMA connector, mating with an SMA can sometimes cause severe damage to the 3.5 mm connector. To ensure measurement accuracy, use 3.5 mm precision connectors. However, you can use SMA connectors if special care is taken when mating the connectors, and all connectors are undamaged and clean.

Most importantly...NEVER turn the measurement standards as a way of tightening the connection. As tempting and easy as it may be, this is a SURE way to destroy the 3.5mm connector. Always, always, always use a torque wrench (even if you seen one of us not using a torque wrench!)

The LAB (parts ripped directly from online help)

<http://ena.tm.agilent.com/e5071c/manuals/webhelp/eng/> (it's not plagiarism if I am not claiming I wrote it right?)

Set up Sweep

1. Press **Channel Next/Channel Prev** keys to select the channel for which you want to set the sweep type.
2. Press **Sweep Setup > Sweep Type**.

3. Press the desired softkey for Linear Freq.
4. Click **Start**, then input 1 MHz.
5. Click **Stop**, then input 1 GHz.

CAL Procedure

- 1) Press **Channel Next/Channel Prev** keys to select the channel for which you want to perform the calibration.
- 2) Press **Cal** key.
- 3) Click **Calibrate > 2-Port Cal**.
- 4) Click **Select Ports**, then select the [test ports](#) on which you will perform full 2-port calibration. (In the procedure below, the selected test ports are denoted as x and y.)
- 5) Click **Reflection**.
- 6) Connect an OPEN calibration standard to test port x (the connector to which the DUT is to be connected).
- 7) Click **Port x Open** to start the calibration measurement (**x** denotes the test port to which the standard is connected).
- 8) Disconnect the OPEN calibration standard and replace it with a SHORT calibration standard.
- 9) Click **Port x Short** to start the calibration measurement (**x** denotes the test port to which the standard is connected).
- 10) Disconnect the SHORT calibration standard and replace it with a LOAD standard.
- 11) Click **Port x Load** to start the calibration measurement (**x** denotes the test port to which the standard is connected).
- 12) Repeat the above procedure for port y.
- 13) Click **Return**.
- 14) Click **Transmission**.
- 15) Make a THRU connection between ports x and y (between the connectors to which the DUT is to be connected).
- 16) Click **Port x-y Thru** to start the calibration measurement (**x** and **y** denote the test ports between which the THRU connection is being made).

- 17) Click **Return**.
- 18) If an isolation calibration must be performed using a LOAD standard, follow the procedure below.
- 19) Click **Isolation (Optional)**.
- 20) Connect a LOAD standard to each of the two test ports (connectors to which the DUT is to be connected).
- 21) Click **Port x-y Isol** to start the calibration measurement (**x** and **y** denote the port numbers to which the LOAD standard is connected).
- 22) Click **Return**.
- 23) Click **Done** to terminate the full 2-port calibration process. Upon pressing this key, calibration coefficients will be calculated and saved. The error correction function will also be automatically enabled.
- 24) Connecting standards in full 2-port calibration

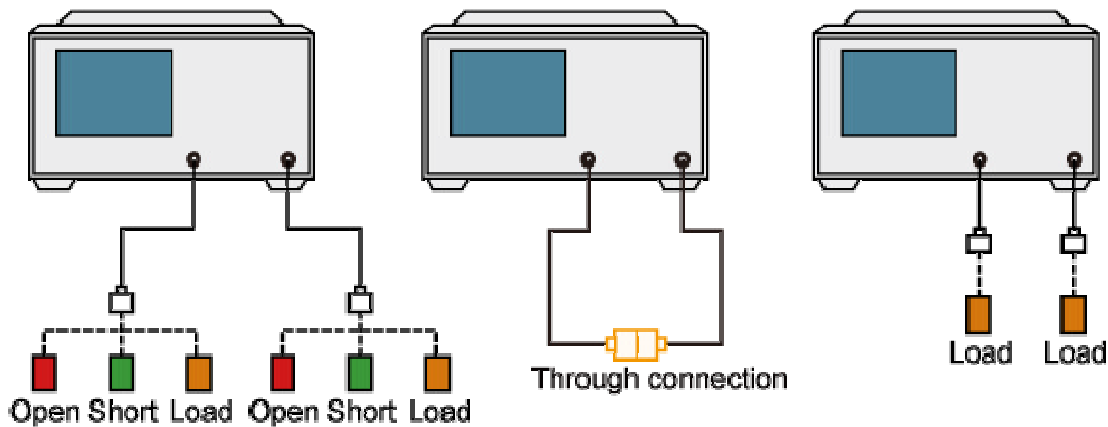

e5071c331

Wasn't that fun?

Now, let's see how good our calibration was.

- 1) Put the short back on port 1.
- 2) Press **Channel Next** (or **Channel Prev**) and **Trace Next** (or **Trace Prev**) to select the trace for which measurement parameters will be set up.

- 3) Press **Meas**.
- 4) Click the softkey that corresponds to S11.

Now...set the display format to Smith Chart

- 5) Press **Channel Next** (or **Channel Prev**) and **Trace Next** (or **Trace Prev**) to select the trace for which the data format will be set.
- 6) Press **Format**.
- 7) Press the softkey that corresponds to "Smith - R + jX"
 - a. Now, your next question may be: What is a Smith Chart?

A smith chart is a convenient representation of the impedance plane. In fact it shows the entire impedance plane for all impedances with positive real resistance, and +/- infinite reactance. Which, in my opinion, is pretty darn spiffy. Shown below is a smith chart and some sample values

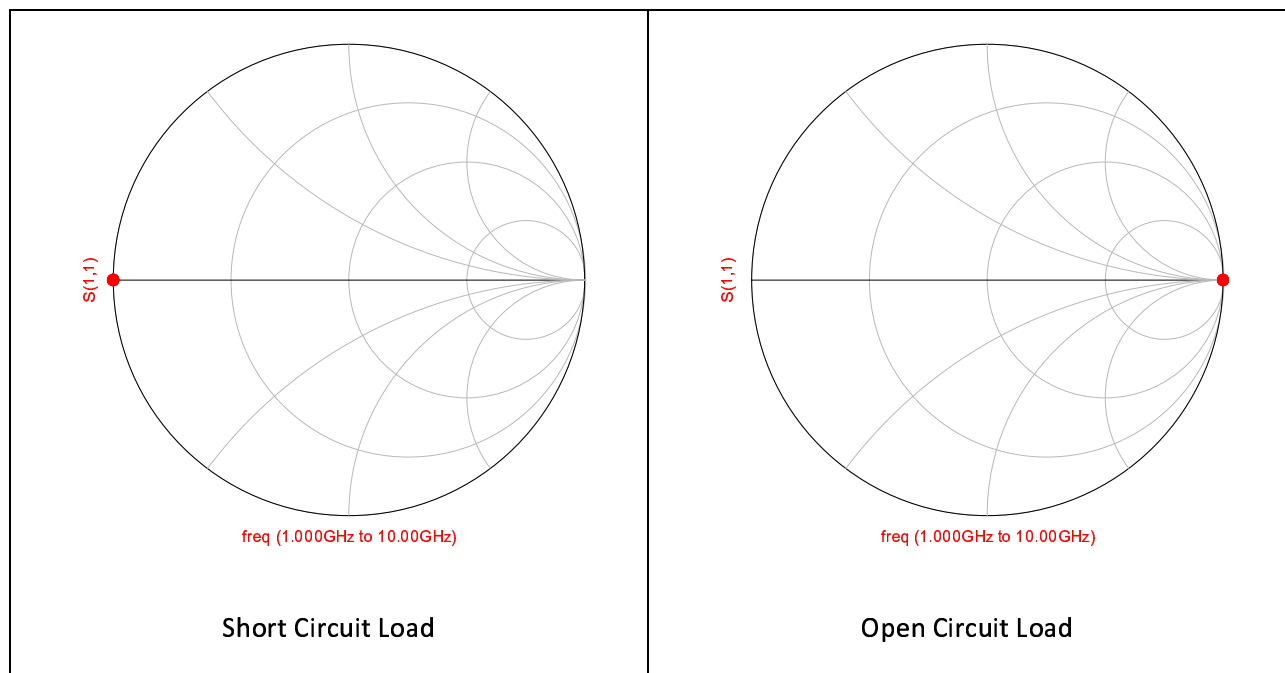

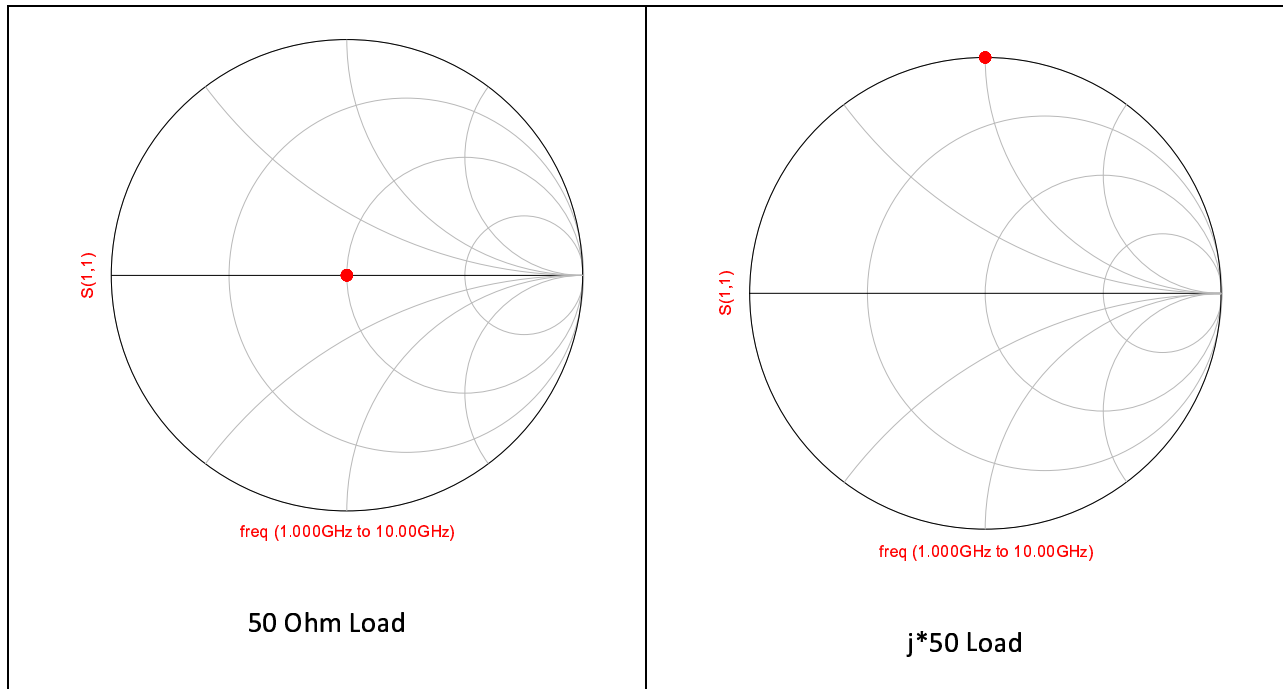

- 8) Now, with the short on port one, and looking at the plots on the previous page you should see something similar to the plot for the short circuit load. On the following plot, attempt to draw what you actually see. (or...if you can figure out how to get it out of the analyzer you can paste a plot here)

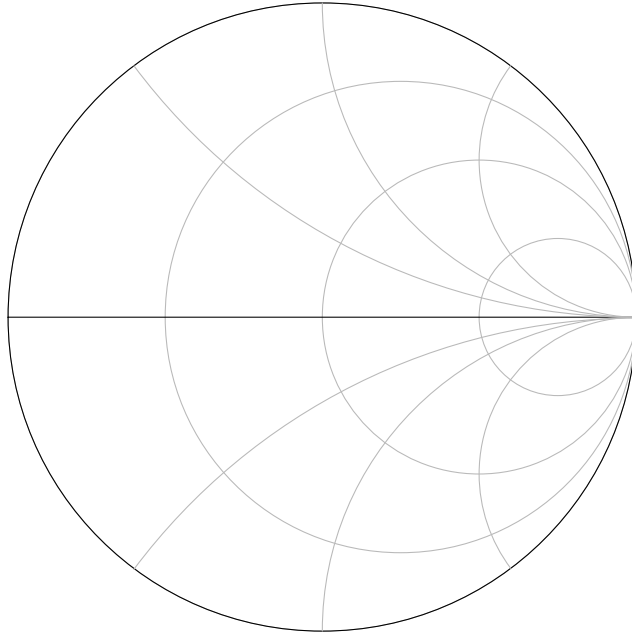

9) Now, remove the short and put on the open. What do you see now? Again, plot it below.

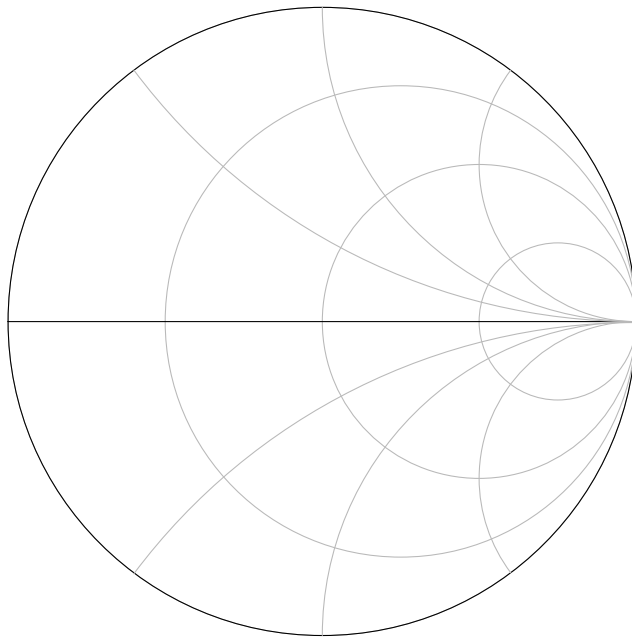

Do your plots look similar to the reference ones shown above? If not, can you guess why not? Hint (reference planes shift around depending on calibration kits etc). For extra credit, see if you can find the

electrical delay setting for port one and port two...see if you can adjust either port's electrical delay so that the data falls exactly where it is supposed to. You can attach a copy of the printout (or just show one of us and we will initial here: _____

10) Remove the open and hook port one and port two together as you did during the calibration.

11) Change your measurement to S21 (your days of keypunch instructions are over).

12) Change the format to Log Mag

13) Press Autoscale, or scale down to the point to where you can see the variation. Record the variation below in dB

+/- _____ dB

How does this seem to you?

What percent variation is this?

14) Now, try moving the cables around gently. Putting some minor bends and such in them (very minor...don't go overboard). Do you see any variation? How much? Is this significant?

15) Now, set the format of S21 to Phase instead of Log Magnitude.

16) How much variation do you see in the phase across the frequency band. Is this significant? Ideally after a call, you should have constant 0 phase across the band. Do you see something other than that? What might have caused it if you do?

This ends the calibration lab. Congratulations, you now hopefully know a little more about calibration of network analyzers than you did before. If you don't, then this was an easy lab for you! Don't worry, they'll get harder!